

# FLEXTECH INDUSTRIES ENGINEERING DATA

## MOVEMENTS

Flextech fabric expansion joints are suitable for any combination of movements as outlined below.

- 1. Axial Movement** - The amount of duct growth which compresses or extends the face to face dimension of the expansion joint.

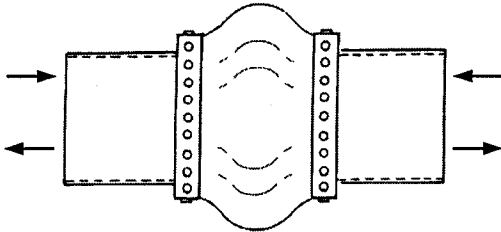

- 2. Lateral Movement** - The amount of duct movement occurring in X or Y direction perpendicular to the longitudinal axis of the ducting system

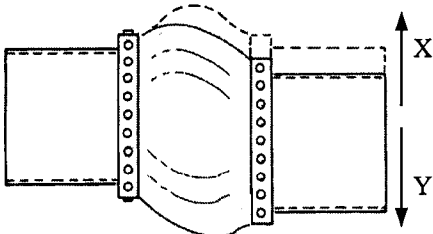

- 3. Angular Deflection** - The amount of movement (in degrees) of the duct system which moves one of the expansion joint ends out of parallel with the other.

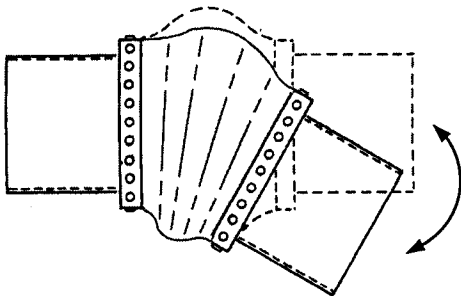

- 4. Torsional Rotation** - The amount of rotational movement of the ducting system which will twist one end of the expansion joint with respect to the other end about its longitudinal axis.

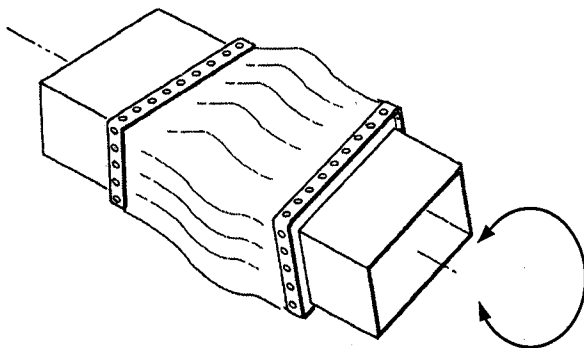

## SET BACK

The distance the expansion joint (flexible element) is moved outward from the gas stream. this allows for lateral movements and prevents the expansion joint from protruding into the gas stream or rubbing on baffle when operating under negative pressures. Proper setback also reduces thermal transfer effect on inner face of expansion joint and prevents abrasion from particles in the gas stream.

## ACTIVE LENGTH

It is important to install the expansion joint properly, the active length on the dimensional data table for frame selection illustrates movements tabulated for four different breech openings.

Consult Flextech for the proper length if other movements are present in the system.

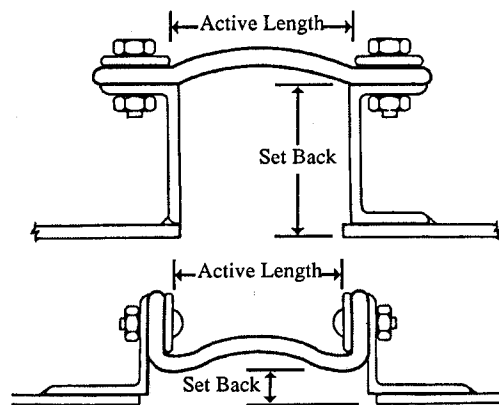

Pressure ±	Active Length	Min. Set Back	
		Frame Type 1 & 2	Frame type 3, 4 & 5
Positive	6" - 7"	1"	4"
Negative	6" - 7"	2"	5"
Positive	9" - 10"	1"	4"
Negative	9" - 10"	3"	6"
Positive	12" - 13"	2"	4"
Negative	12" - 13"	4"	6"
Positive	16" - 17"	2"	6"
Negative	16" - 17"	5"	7"

Manufacturing procedures may require slightly greater set backs, special clearance restrictions should be specified.

